

REVISION HISTORY	
1	Original Part
2	Hole dimension added (H)

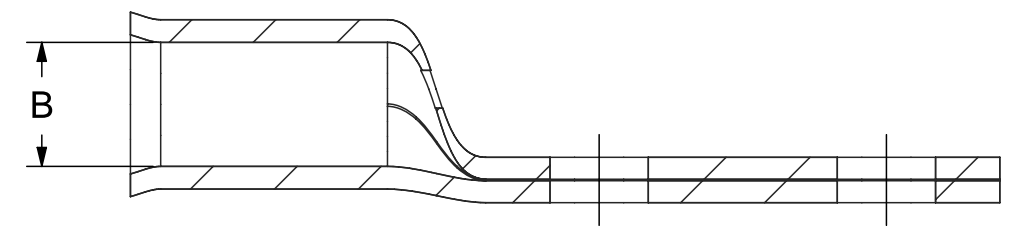

SCALE 1:1

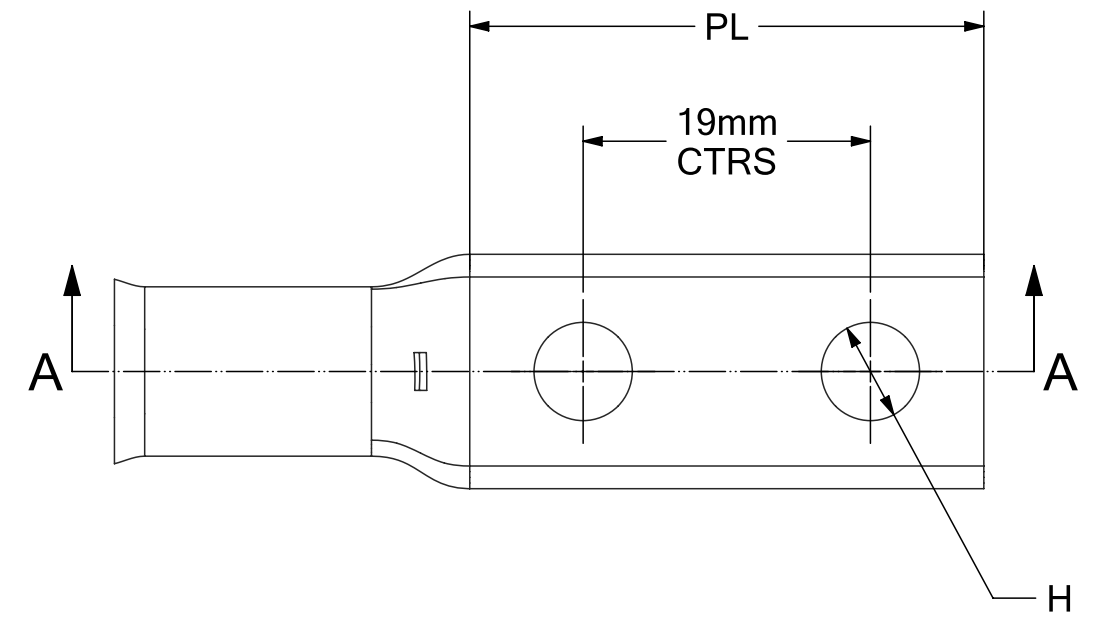

SECTION A-A

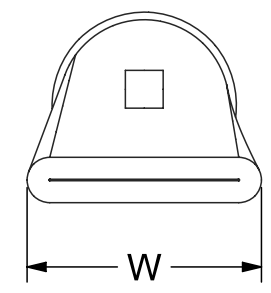

PART NO.	H (mm)	W (mm)	PL (mm)	B (mm)
TC2H-19C-4-5	5.5	11.0	34.0	3.0
TC2H-19C-4-6	6.5	11.0	34.0	3.0
TC2H-19C-4-8	8.5	11.0	34.0	3.0
TC2H-19C-6-5	5.5	11.0	34.0	4.1
TC2H-19C-6-6	6.5	11.0	34.0	4.1
TC2H-19C-6-8	8.5	11.0	34.0	4.1
TC2H-19C-10-5	5.5	11.0	34.0	4.4
TC2H-19C-10-6	6.5	11.0	34.0	4.4
TC2H-19C-10-8	8.5	11.0	34.0	4.4
TC2H-19C-16-5	5.5	11.4	34.0	5.6
TC2H-19C-16-6	6.5	11.4	34.0	5.6
TC2H-19C-16-8	8.5	11.4	34.0	5.6
TC2H-19C-25-5	5.5	13.5	34.0	7.0
TC2H-19C-25-6	6.5	13.5	34.0	7.0
TC2H-19C-25-8	8.5	13.5	34.0	7.0
TC2H-19C-35-5	5.5	15.5	34.0	8.2
TC2H-19C-35-6	6.5	15.5	34.0	8.2
TC2H-19C-35-8	8.5	15.5	34.0	8.2
TC2H-19C-50-5	5.5	17.2	34.0	9.5
TC2H-19C-50-6	6.5	17.2	34.0	9.5
TC2H-19C-50-8	8.5	17.2	34.0	9.5

UOS - LINEAR TOLERANCE PERMISSABLE DEVIATIONS FOR SIZE RANGE:
Tolerances according to DIN ISO 2768 (V)

DIMS IN MM	0.5 to 3	>3 to 6	>6 to 30	>30 to 120	>120 to 400	>400 to 1000	>1000 to 2000	>2000 to 4000
	-	±0.5	±1.0	±1.5	±2.5	±4.0	±6.0	±8.0

TOTAL CONNECTIONS 2009

Total Connections 2009 LTD

www.tc2009.co.uk
sales@tc2009.co.uk
Tel 01249 812 707

Drawing No. TCDR2307 Material. CW024A (C106) COPPER

Part No. TC2H-19C-RANGE Finish. 5MICRON ELECTRO TIN PLATED

SIZE A3 Date 23/11/2021 Created By: Dan Hewlett REV 2

SCALE 2:1 SHEET 1 of 1